

ELECTRONIC FLOW CONTROL SWITCH

FLUX

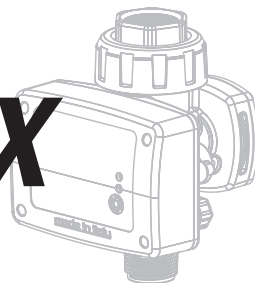

FLUX® is a device that starts and stops the pump to which it is fitted. The pump installed with positive suction head or water supplied with aqueduct is started when a tap is turned on to generate a flow and is stopped when the flow rate required is zero or less than the "shut-off flow rate" (Qa).

Technical specifications

- Voltage: ~ 230 V / ~ 115 V -
- Frequency: 50-60 Hz
- Current: 12A, max 16A for 3 sec.
- Protection grade: IP 65
- Run/stop flow rate (Qa) : = 2 l/min (0,5 gpm)
- Connections: 1" M BSP / 1" M NPT
- Operating pressure: 10 bar (145 psi)
- Bursting pressure: 24 bar (350 psi)
- Weight: 650 g
- Max liquid temperature: 55°C

Before installing the product, check that the RATINGS correspond with those required.

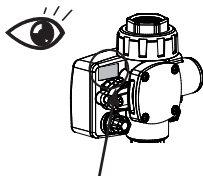

CODE: **50066/115**
 V / Hz: **230 / 50 - 60**
 I max: **16 A**
 Year: **2015** **B**

Losses

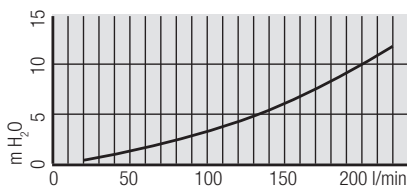

Operating conditions

A. Compatible/non compatible fluids FLUX® is suitable for use with clean water and chemically non-aggressive liquids. If the fluid contains impurities, a filter should be fitted upstream.

B. Environmental conditions FLUX® should not be used where there is the risk of an explosion. The temperature of the location should range between 0°C and 40°C, and the humidity should not exceed 90%.

C. Power supply Make sure that the variation in

Safety regulations

Before installing or using FLUX®, read this manual carefully and thoroughly. The pump should be installed and serviced by qualified personnel, responsible for making the hydraulic and electrical connections in compliance with the relevant regulations.

DGFLOW® shall not be held liable for any damage relating to, or resulting from, an improper use of the product, or for any damage relating to, or resulting from, servicing or repairs carried out by unqualified personnel and/or with non-OEM spare parts. The warranty, which is valid for 24 months from the date of purchase, will no longer be applicable should the product suffer damage as a consequence of the use of non-OEM spare parts, tampering or improper use.

When starting the installation, check the following:

- the power supply is switched off.
- the power lines can withstand the maximum current.
- the cable bushings and circuit board cover have been properly assembled and secured (see Electrical Connections).
- the power supply is fitted with regulation earthing and safety devices.

When servicing the product, check the following:

- the system is not pressurised (turn a tap on)
- the power supply is switched off.

Emergency Stop

When in use, the pump can be stopped in the event of an emergency:



press STOP/RESTART

FLUX® is put STAND-BY.

Working Area

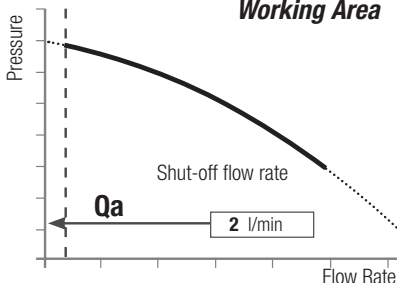

the power supply is never more or less than 10 % of the RATING value. Higher values may cause damage to the electronic

components. FLUX® can only be used with single-phase pumps.

Installation

Preliminary checks

Take the FLUX® out of the packaging and check the following:

- check for damage,
- check the RATINGS correspond with those required,
- that the cable bushings and screws are in place,
- that FLUX®'s inlets and outlets are clean and free of any packaging materials,
- that the check valve moves smoothly.

Hydraulic connections

the joint in two pieces allows rapid connection to the system. DO NOT apply sealant inside the 2-piece joint because it already has an internal o-ring.

Orientation

FLUX® can be installed at any angle depending on the flow direction, as indicated in the diagrams.

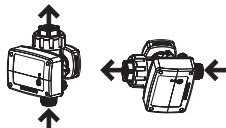

Position

FLUX® can either be fitted directly to the pump discharge or anywhere along the delivery or suction line, but in any case upstream outlet network. No taps have to be installed between the pump and FLUX®.

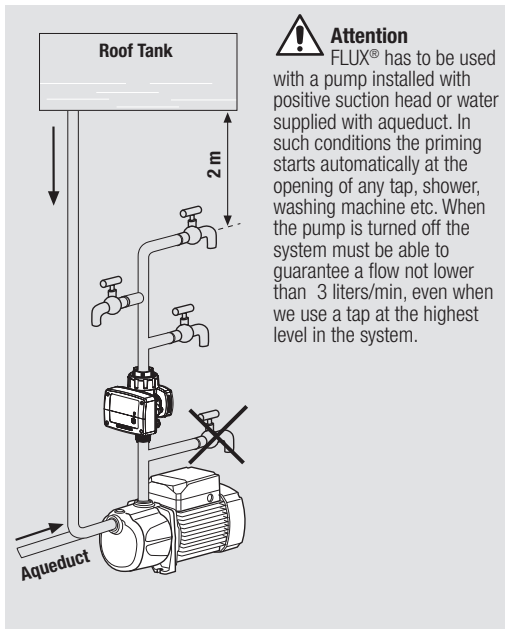

Attention
FLUX® has to be used with a pump installed with positive suction head or water supplied with aqueduct. In such conditions the priming starts automatically at the opening of any tap, shower, washing machine etc. When the pump is turned off the system must be able to guarantee a flow not lower than 3 liters/min, even when we use a tap at the highest level in the system.

• First start-up

Priming the pump

For instructions on how to prime (fill) the pump, see the pump manual.

Switching the pump on

The red (POWER ON) LED lights up; FLUX® instantly goes in standby and at the request of water starts the pump (the green "PUMP ON" LED lights up).

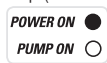

15 seconds after the flow has become zero or got under the value 1-2 liters/min FLUX® stops the pump and goes in standby (only the red (POWER ON) LED is on)



Electrical connections

The electrical connections should be made as indicated in the diagram which can also be found on the inside of the circuit cover.

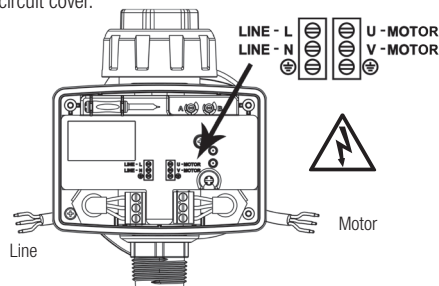

Attention! The cable bushings and circuit board cover must be properly assembled and secured in order to guarantee IP 65 grade protection of the electrical components.

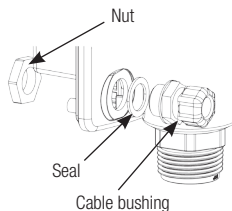

NOTE 1 - DRY RUNNING = there is no flow. It occurs when there is no water. After 15 seconds FLUX stops the pump. If FLUX detects flow, NORMAL SERVICE is AUTOMATICALLY resumed.

Operation

1 NO POWER SUPPLY

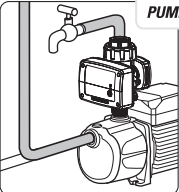



POWER ON

PUMP ON

- FLUX® is switched off.
- **PRESS BRIEFLY** or **HOLD DOWN** = nothing happens.

• **Power is restored** = FLUX® resumes NORMAL SERVICE and starts the pump (if necessary).

STOP RESTART 



2a NORMAL SERVICE: the pump is inactive.

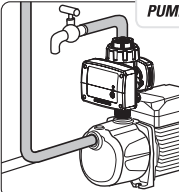

POWER ON

PUMP ON

- All taps are turned off. There is no demand for water. FLUX® detects no flow.
- **PRESS BRIEFLY** = the pump is started manually and runs for a few seconds before stopping again.
- **HOLD DOWN** = the pump is put STAND-BY. For instructions on how to reactivate the pump, see point 3.
- **A tap is turned on** = as soon as the flow goes over the shut off rate the pump is started.

STOP RESTART 



2b NORMAL SERVICE: the pump is running.

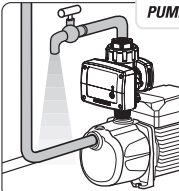

POWER ON

PUMP ON

- The assembly requires water. One or more taps are turned on. FLUX® detects a flow higher than the shut off rate.
- **PRESS BRIEFLY** = the pump is stopped and put STAND-BY. For instructions on how to reactivate the pump, see point 3.
- **The taps are turned off** = if there is no flow for a few seconds, the pump is stopped.

STOP RESTART 



2c NORMAL SERVICE: pump during shutdown

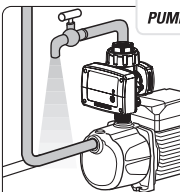

POWER ON

PUMP ON  • • • • •

The system has just ceased to require water. All taps are closed. FLUX detects the absence of flow.

PRESS BRIEFLY or **HOLD DOWN** = the pump is stopped and put in STAND-BY

To reset see point 3.

If the absence of flow lasts for a few seconds the pump is stopped

STOP RESTART 

3 STAND-BY

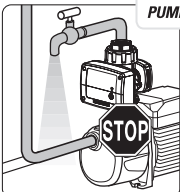

POWER ON  • • • • •

PUMP ON

• The pump has been stopped manually. The pump will remain inactive until a new command is given.

• **PRESS BRIEFLY** = nothing happens.

• **HOLD DOWN** = the pump resumes NORMAL SERVICE. See points 2a - 2b.

STOP RESTART 

= Off

= On

 = Flashing

Problems	Signals	Possible causes	Solutions
FLUX® will not turn on	POWER ON ○ PUMP ON ○	A - No power	A - Check the electrical connections
The pump will not start when a tap is turned on	POWER ON ● PUMP ON ○	B1 - The pump will not start when a tap is turned on	B1-1 - Check whether there is incoming water in the suction pipes B1-2 - Open the tap more B1-3 - Modify the system so that even when the pump stops, flow rates higher than 3 liters/min can be generated at the opening of a tap
	POWER ON ● PUMP ON ○	B2 - FLUX® does not detect a flow even when replace the circuit board	B2-1 - Change circuit board
	POWER ON ● PUMP ON ●	B3 - Faulty electrical connections or pump out of service	B3-1 - Check the electrical connections and that the pump is working
	POWER ON ☀..... PUMP ON ○	B4 - FLUX® is in STAND-BY state	B4-1 - Turn on FLUX® again (see Operation, point 3)
	POWER ON ● PUMP ON ☀.....	B5 - FLUX® is near to stop because of insufficient flow	B5-1 - None; restore the flow
The pump delivers no or low pressure	POWER ON ● PUMP ON ●	C1 - Filters or pipes may be partly blocked	C1-1 - Check the water pipes
	POWER ON ● PUMP ON ●	C2 - FLUX®'s valve will not open completely	C2-1 - Check that the valve is not blocked by any foreign objects and clean if necessary
The pump will not stop	POWER ON ● PUMP ON ●	D1 - Leaks in the system are higher than the shut-off flow rate (Qa)	D1-1 - Make sure that all taps are turned off and that there are no leaks within the system
	POWER ON ● PUMP ON ●	D2 - FLUX®'s check valve will not close	D2-1 - Check that the valve is not blocked by any foreign objects and clean if necessary

○ = Off

● = On

☀ = Flashing

Exploded view of spare parts

Attention: when ordering spare parts, always state the position n° from the diagram below and the product code number found in the flow regulator technical data table.

- 1 - Circuit board cover
- 2 - Circuit board
- 3 - Cable bushings
- 4 - Valve kit
- 5 - Pressure gauge
- 6 - 2 pieces-joint

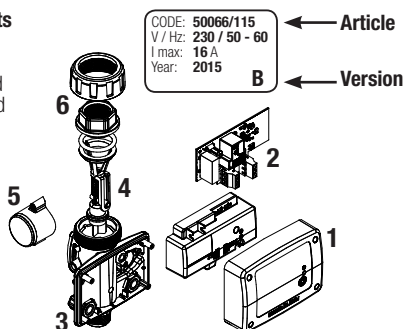

Dimensions

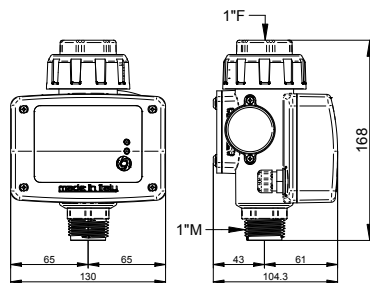

Disposal

When disposing of any FLUX® parts, adhere to the relevant laws and regulations in force in the country in which the equipment is being used. Do not dispose of any polluting parts in the environment.



Statement of Compliance: we declare, under our own responsibility, that the product in question is in compliance with the following European Directives and national implementation provisions

2014/35/CE Low Voltage Directive
2002/95/CEE (RoHS)
2002/96/CEE - 2003/108/CEE (WEEE)
2014/30/CE Electromagnetic Compatibility Directive (EMC)
EN 60730-2-6
EN 61000 6-3

Bigarello 06.02.15

DGFLOW S.r.l.
President
Stefano Concini

Made in Italy by

DGFLOW srl Via Emilia, 5
46030 Bigarello (Mantova) Italy
tel. +39 0376 340922
fax. +39 0376 249525
info@dgflow.it - www.dgflow.it